

COLLECTION LES 100 CIELS
MATELAS
Matrassen

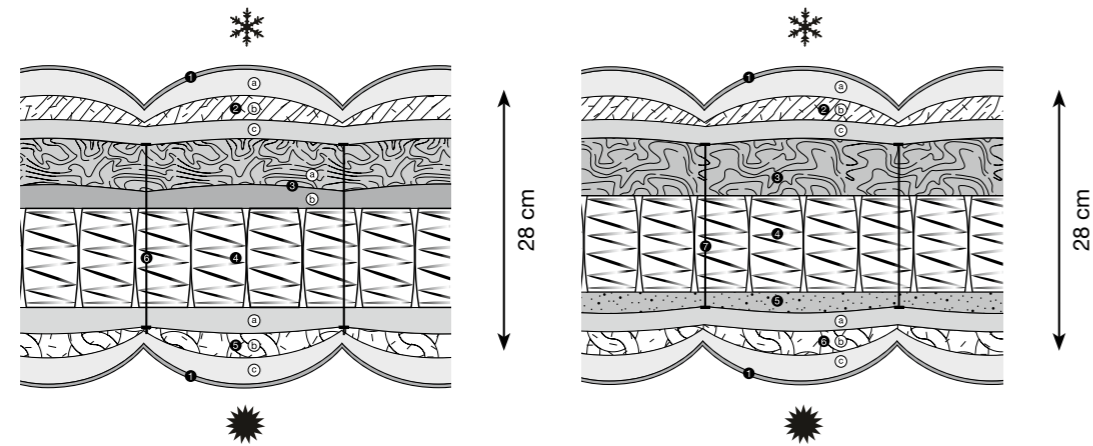

CLAIR DE LUNE



1. Coutil
1. Drell

2. climatique face hiver :
a) ouate - 300 g/m²
b) biolaine 200 g/m²
c) mousse - 17 mm

2. Winterseite:
a) Watte 300 g/m²
b) Bio-Wolle 200 g/m²
c) Schaumstoff 17 mm

3. enrobage face hiver :
a) viscoélastique - 40 mm
b) mousse 15 mm

3. Aufpolsterung:
a) viskoelastischer Schaumstoff 40 mm
b) Schaumstoff 15 mm

4. Suspension ressorts ensachés
4. Taschenfederkern

5. climatique face été :
a) mousse - 17 mm
b) coton lin bio 200 g/m²
c) ouate - 300 g/m²

5. Sommerseite:
a) Schaumstoff 17 mm
b) Baumwolle und Bio-Leinen 200 g/m²
c) Watte 300 g/m²

6. Capitonage integral
6. Innere Abheftung

GRAIN DE FINESSE



1. Coutil
1. Drell

2. climatique face hiver :
a) ouate - 300 g/m²
b) biolaine 200 g/m²
c) mousse - 17 mm

2. Winterseite:
a) Watte 300 g/m²
b) Bio-Wolle 200 g/m²
c) Schaumstoff 17 mm

3. enrobage face hiver : latex naturel 17 mm
3. Aufpolsterung: Naturlatex 17 mm

4. Suspension ressorts ensachés
4. Taschenfederkern

5. climatique face été :
a) mousse - 17 mm
b) coton lin bio 200 g/m²
c) ouate - 300 g/m²
5. Sommerseite:
a) Schaumstoff 17 mm
b) Baumwolle und Bio-Leinen 200 g/m²
c) Watte 300 g/m²

6. Capitonage integral
6. Innere Abheftung

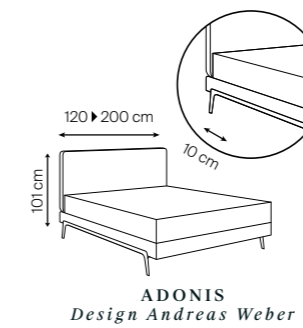

ADONIS
Design Andreas Weber

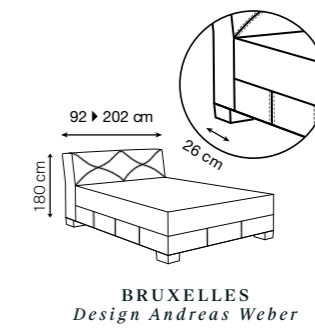

BRUXELLES
Design Andreas Weber

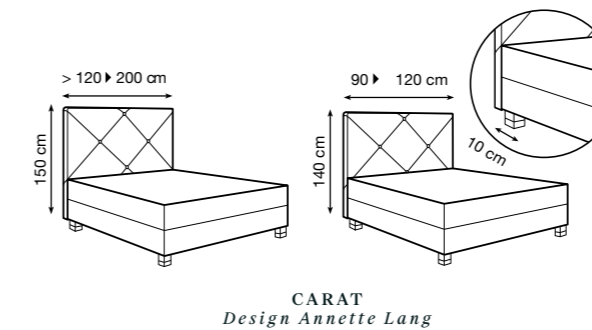

CARAT
Design Annette Lang

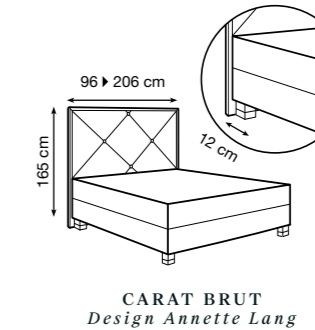

CARAT BRUT
Design Annette Lang

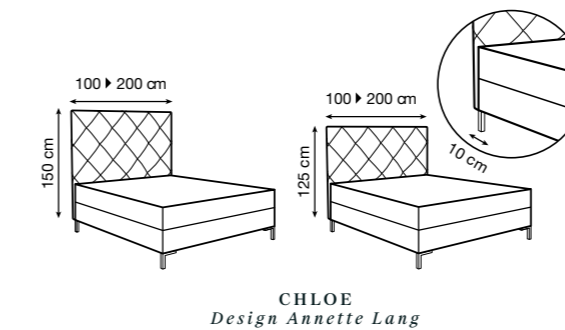

CHLOE
Design Annette Lang

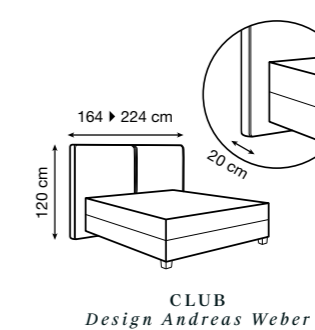

CLUB
Design Andreas Weber

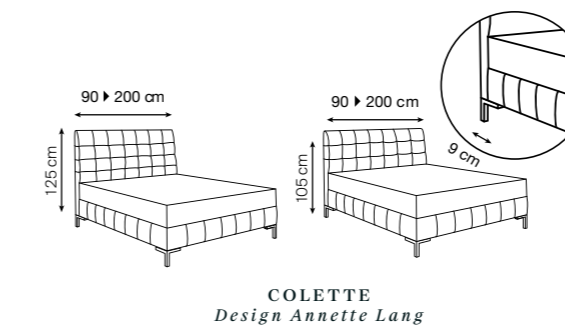

COLETTE
Design Annette Lang

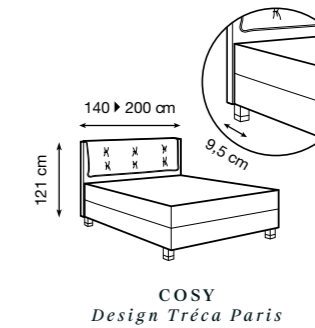

COSY
Design Tréca Paris